

**DÜRMEIER**

**ANLAGENBAU & VERFAHRENSTECHNIK**

MIX  
**CONVEY**  
SIEVE DOSE  
ENGINEERING  
**STORE**



## The company Dürmeier GmbH – Made in Germany

Perfect industrial equipment – this is what Dürmeier GmbH stands for. State-of-the art engineering, perfection in production and assembly. More than 40 years of experience and reliability under the "Made in Germany" mark.

We provide equipment for different applications, such as chemical industry, mining, foundries, steelmaking and recycling. Our specialization is individual solutions. We are able to satisfy the strictest requirements in industrial operations providing maintenance-free equipment satisfying the modern demands on energy efficiency and sustainability – we apply a “special” approach in situations as if they were “standard”.

Our experienced staff is always at your disposal for this. Concept development and design, production and assembly – all this processes take place hand in hand in one company.

This allows for perfectly matching to existing conditions and interfaces, including risk analysis, documentation preparation and obtaining of CE or EAC conformity declarations. We work both with greenfield turnkey projects or with replacement of individual components at existing plants.

Try us!



# **ENGINEERING**

## **Our strengths**

The strength of the Dürmeier GmbH is to plan the tasks under consideration of existing conditions and to develop an optimal solution.

From the concept, on-site measurement, basic and detail engineering to erection supervision – you will receive all services from a single source. We design dimensions and services in such a way that your requirements will be fulfilled in reliable, resource-conserving manner with minimal wear.

We use our proven modular systems as well as integrated units from other manufacturers for obtaining of optimal overall results.

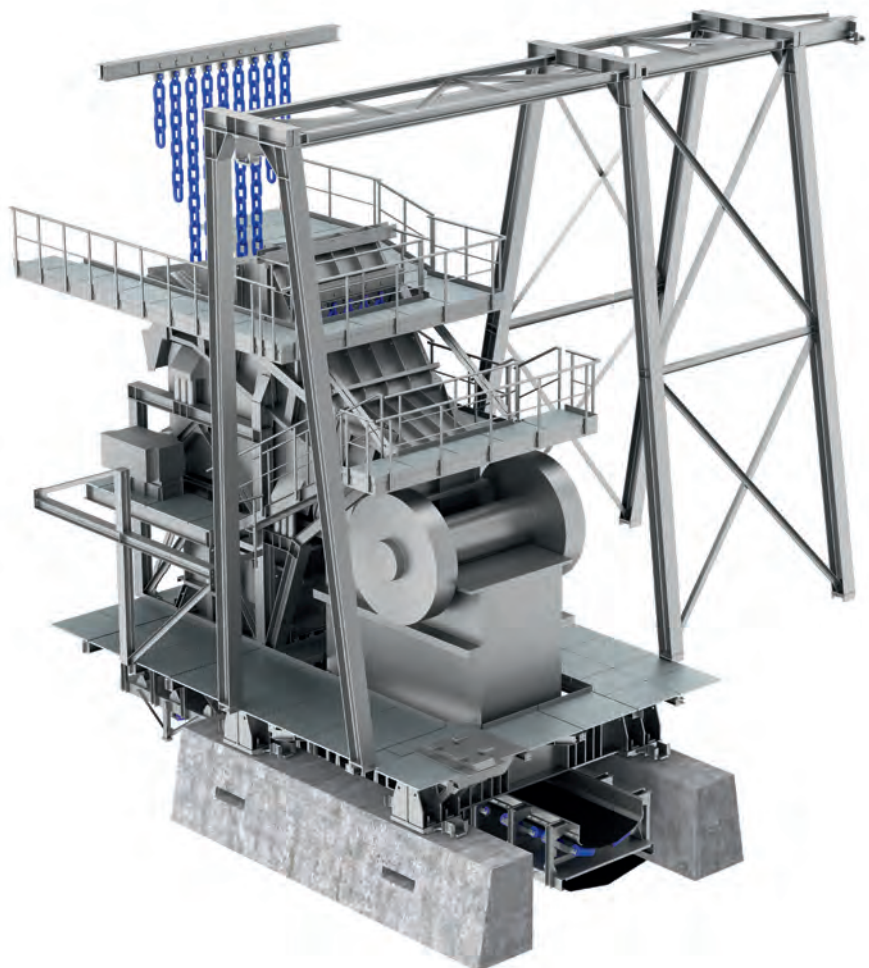



# PACKAGE PLANT SUPPLY

## Turnkey complete solutions

You can receive an individual and turnkey complete solution from a single source.

The range of services includes both the full scope consulting and planning services as well as the full-cycle construction of new plant or the retrofit, expansion or process optimization of an existing plant.

This includes:

- Transportation
- Mixing
- Dosing
- Separation
- Storage
- Control

We use only high-quality components and state-of-the-art technologies. Our personnel are experts in their field and use their deep experience in everyday tasks.

Cooperation with the Dürmeier GmbH means:

- reduced organizational costs
- optimal coordination of supply of all components from different manufacturers
- maximum availability of the entire system

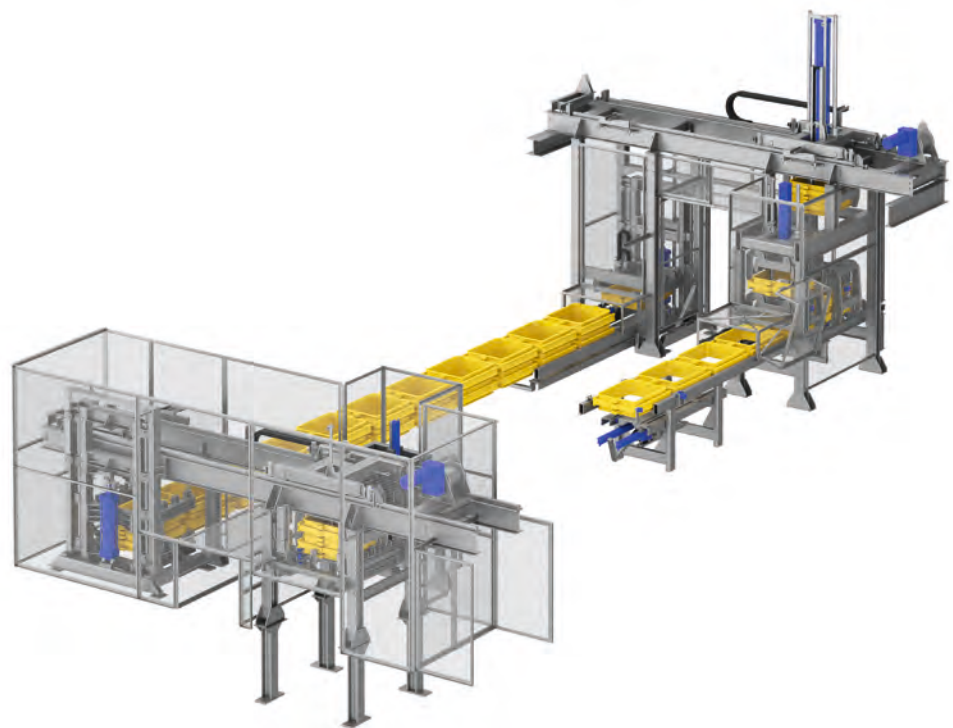

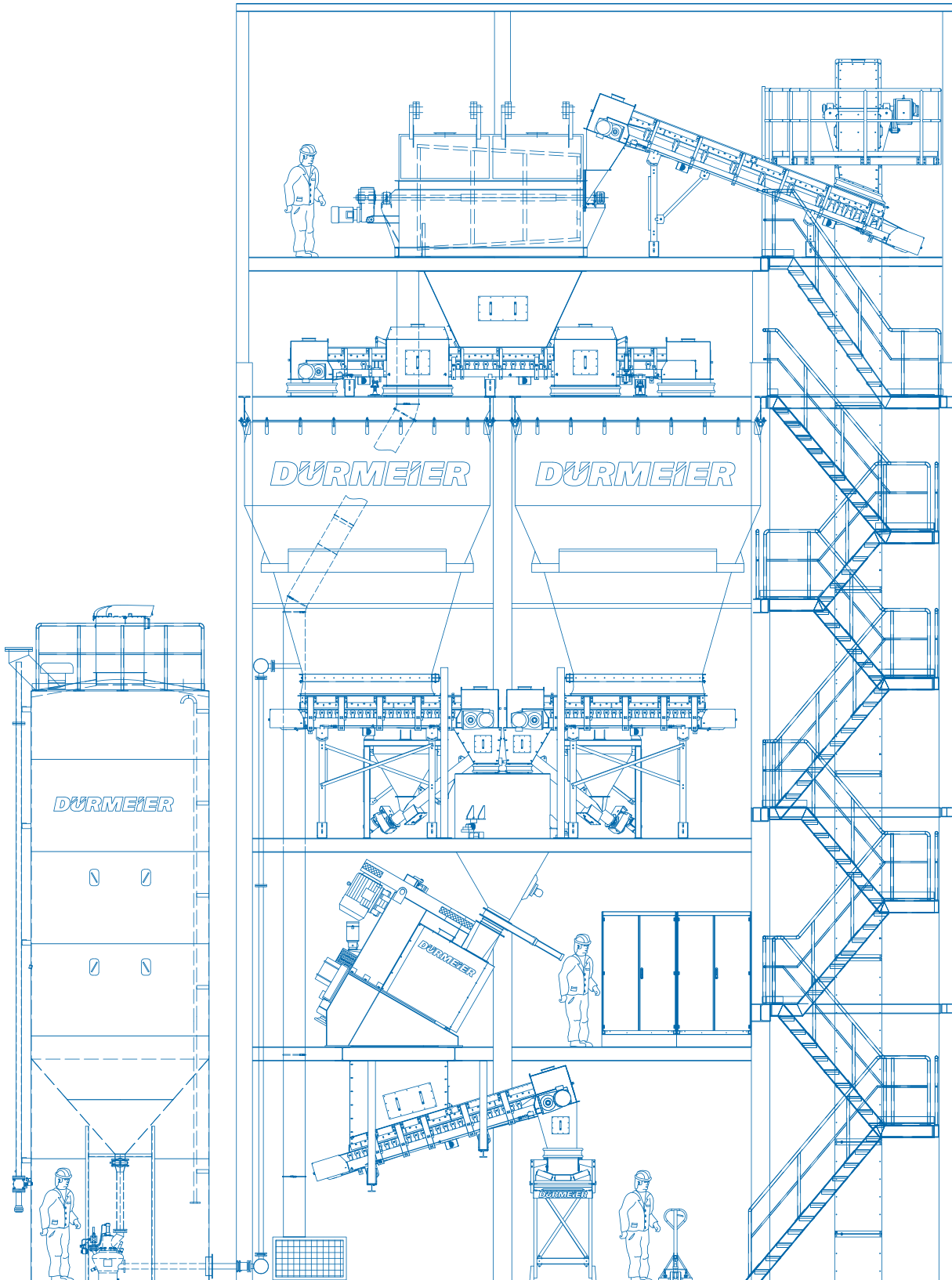



# TRANSPORTATION

## Conveying of bulk materials and general cargo

Horizontal and vertical transportation of bulk materials and general cargo is one of the key expertise of Dürmeier GmbH.

- Capacity – up to 10,000 tons per hour
- Conveyor length – up to 10,000 m
- Max. feed size – 1.50 m
- Height differences with vertical conveyors – up to 100 m
- Ambient temperatures – from -40 °C to +60 °C

If the requirements for your projects are higher, please contact us!

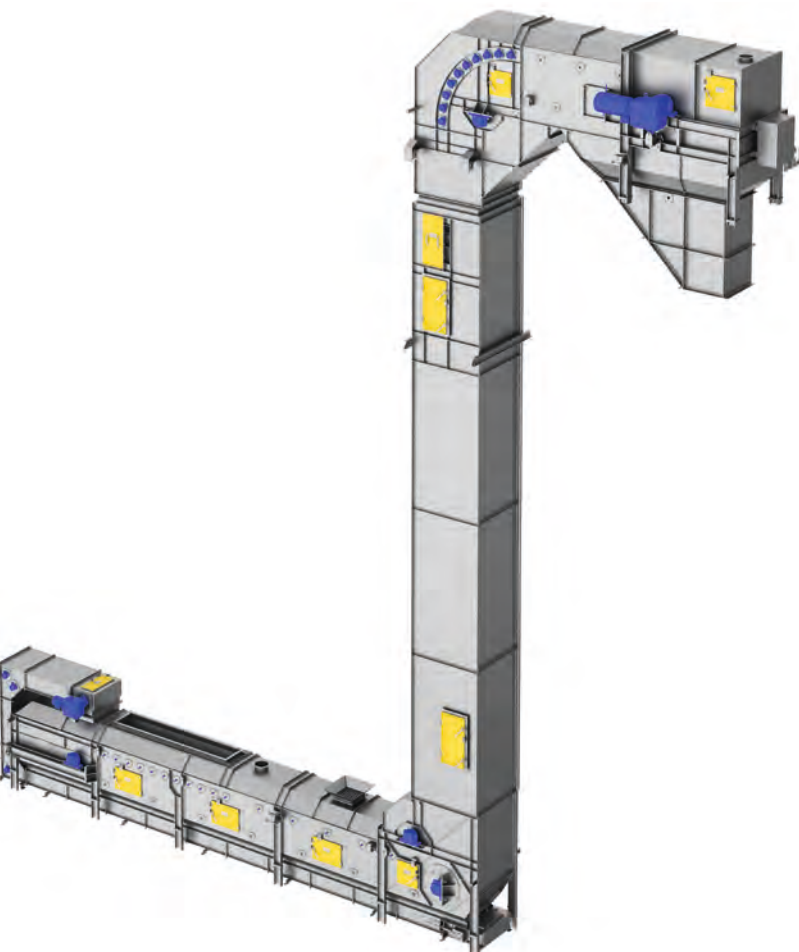

## Solutions

For horizontal and inclined routes:

- Horizontal or inclined belt conveyors
- Belt conveyors for hoppers discharge
- Conveyor troughs and pipes
- Grizzly screens
- Pneumatic conveyors
- Scraper conveyor
- Screw conveyors
- Roller conveyors
- Transverse conveyors
- Flat feeders

For vertical routes:

- Elevators (belt or chain bucket elevators)
- Sidewall conveyor
- Screw conveyors
- Pneumatic conveyors
- Elevating tables

Also, different modifications are available:

- Radial, stationary, movable or swiveling series
- Corrosion resistant materials
- Explosion-proof, dust-proof and flame-retardant versions
- Lightweight, standard or heavy-duty design
- Additional discharge points
- Weighing functions
- Metal separators

Others on request.

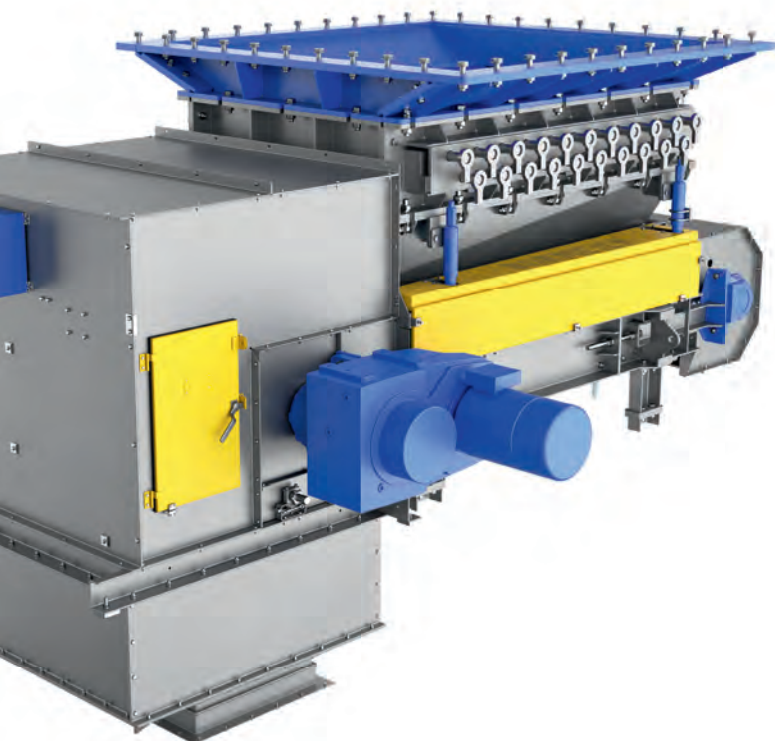



# SCREENING & SEPARATION

## Separate material flows

Material flows can be divided, for example, by particle sizes or other physical properties of material. We are able to select the most appropriate separation technology for you – both for high and low flow rates.

### Solutions

- Cascade screens
- shakeout tables and screen-feeders
- Flat screens
- Multi-deck screens
- Separators and sieves
- Magnetic drums
- Magnetic belt conveyors
- Separator for non-ferrous metals
- Separators for long items

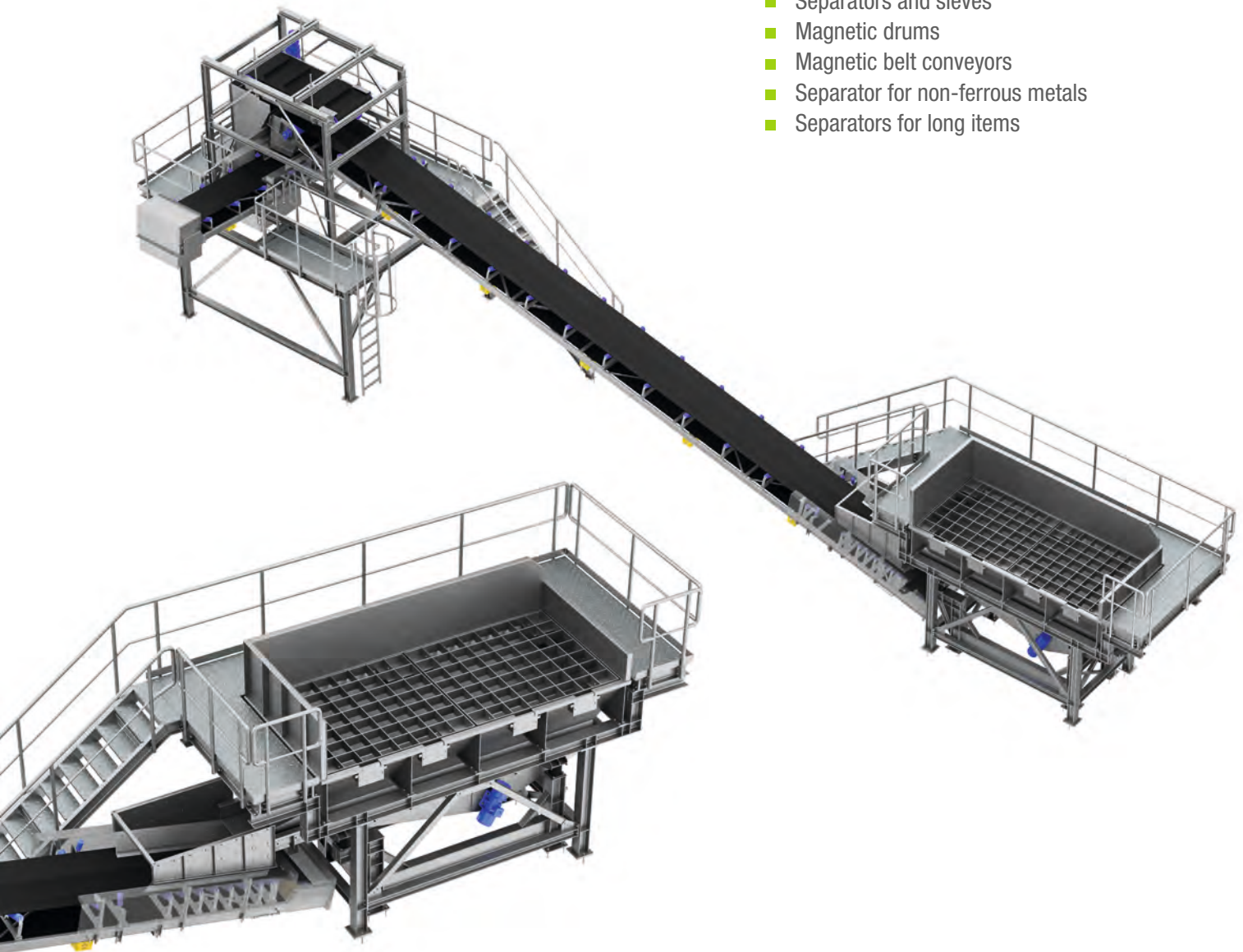



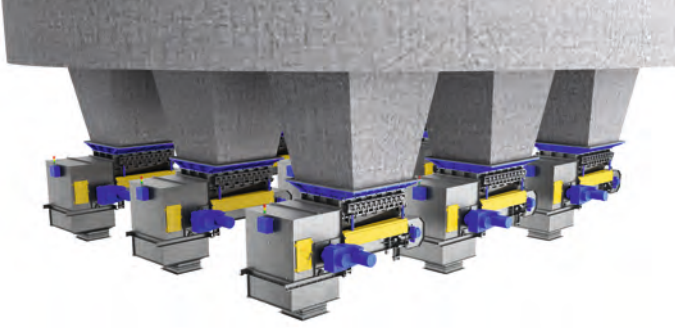

## STORAGE

### Warehousing as a process stage

Storage equipment for delivery, before and after preparation, for homogenization of material flows, before sale or disposal. We integrate the optimal storage concept into your production process, including reliable and continuous material removal.

#### Solutions

- Stockpiles
- Towers and round silos made of steel or plastic
- Containers, hoppers and funnels in different sizes and shapes
- Big-bag emptying and filling stations

#### Special versions

- Corrosion resistant materials
- Dust-proof types
- Explosion protection
- Wear protection or anti-adhesive-lining
- Weighing and control technology



# ▶▶ DOSING

## Batch or continuous dosing

Dosing is an important component for a reproducible production process and has a significant impact on product quality. We plan your dosing concept according to your requirements either as a batch or continuous version.

### Solutions

- Dosing belt conveyor
- Belt feeders
- Screw conveyors
- Chutes
- Gates



# WEIGHING

## Exact determination of volume

We provide services on scales integration to existing systems or installation within greenfield projects. Hoppers, reservoirs, silos, mixers and conveyor belts, at incoming and outgoing products monitoring and for monitoring of process parameters.

### Solutions

- Belt scales
- Feeders
- Bulk flow measurement systems
- Dosing machines
- Conveyor scales for reservoirs
- Load cells
- Weighing modules
- Load cells

Also we are able to provide test services at our headquarters in Vaihingen an der Enz on special customer requests and after feasibility studies.





# MIXING

## Homogeneous mixing

Depending on the application, continuous or batch mixers are applied. Mixing is always aimed to achievement and maintaining of homogeneous and consistent product.

With our mixers, your material can be mixed, pelleted or granulated as needed.

### Solutions

- Turbine mixer
- Mix muller
- Screw mixers

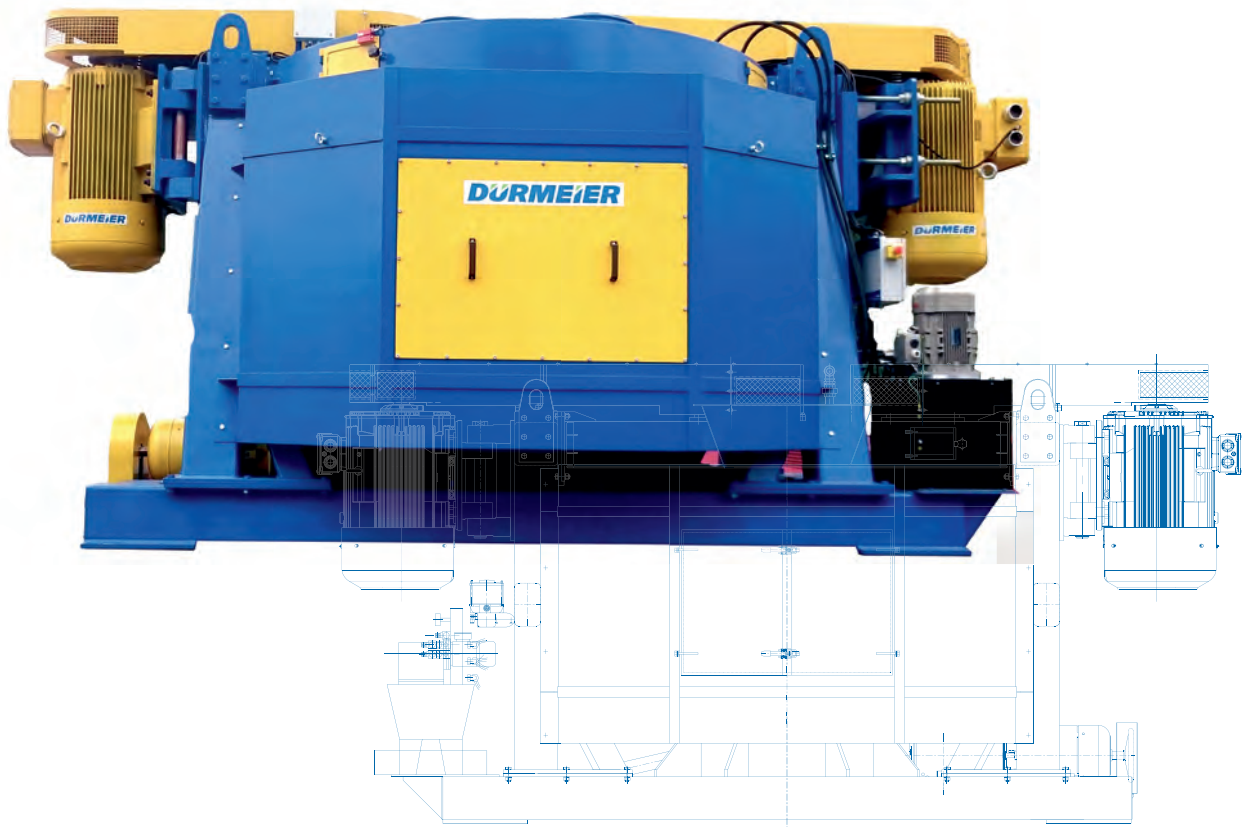

# CONTROL SYSTEMS

## Control systems & process visualization

Transparent process representation is a critical factor for a reliable and continuous production.

With our know-how we can give you maximum transparency.

At your disposal:

- Connection to related control systems
- Control and visualization tools
- Centralized and distributed control cabinets
- Various communication systems
- Electronic measuring devices of any type

Also, we provide service on integration to existing controller or devices from a third-party manufacturer.

Send your request to us!

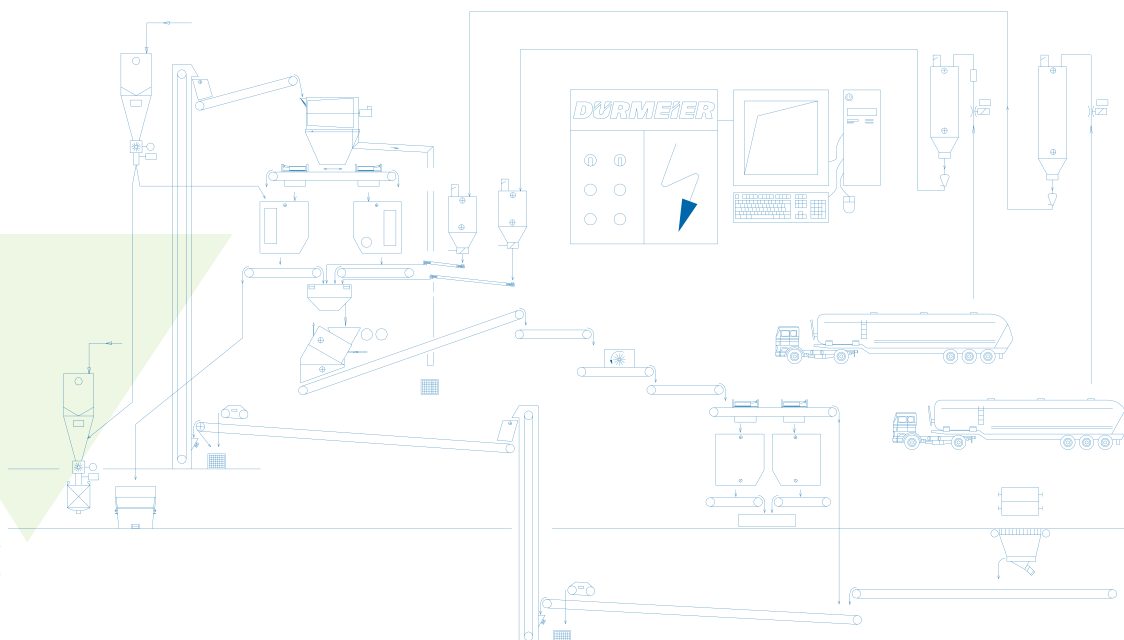



# MOUNTING & SERVICE

## Worldwide on site

Full-cycle services mean:

- Disassembly and disposal of existing plants and components
- Installation and commissioning of systems and components
- Commissioning and acceptance
- Personnel training
- Repair and maintenance services for equipment
- Remote maintenance support via internet and telephone
- Supply of spare and wear parts

With our installation concepts we provide an optimal operation with minimal downtimes.

We also offer service and support for third party equipment.  
Send your request – we please to answer your questions!





MIX  
**CONVEY**  
SIEVE DOSE  
ENGINEERING STORE



**DÜRMEIER**  
ANLAGENBAU & VERFAHRENSTECHNIK

**Dürmeier GmbH**  
**Anlagenbau & Verfahrenstechnik**

Herrenwiesen 8  
71665 Vaihingen/Enz-Ensingen  
Germany

Phone +49 (0) 70 42 - 82 25-0  
E-mail [info@duermeier.de](mailto:info@duermeier.de)

[www.duermeier.de](http://www.duermeier.de)

**Sales office**

E-mail [berlin@duermeier.de](mailto:berlin@duermeier.de)

**Representative office in Russia**

E-mail [ru-office@duermeier.de](mailto:ru-office@duermeier.de)